

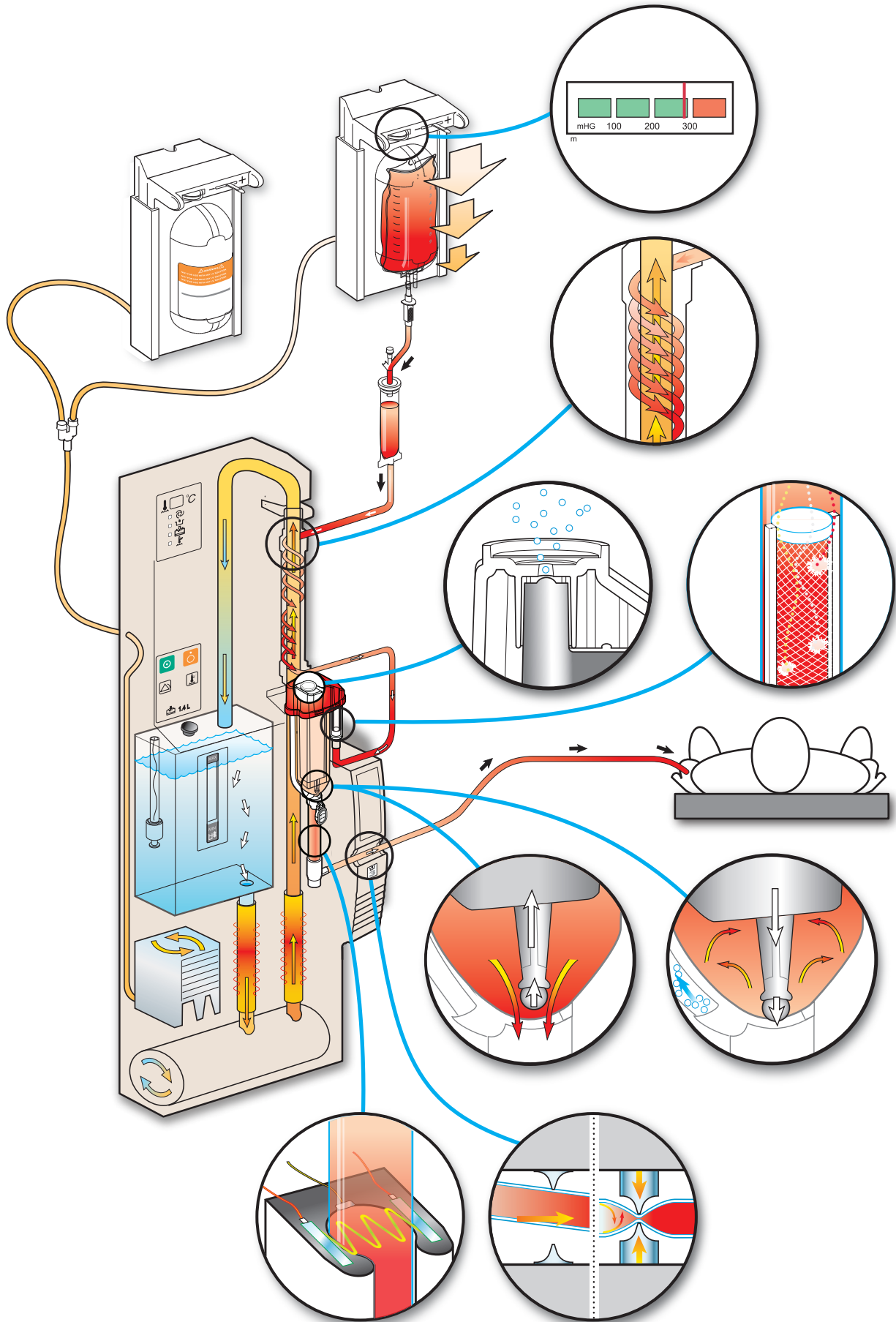

Kristoffer Tronerud

# Illustration & Icon/Symbol Design



**Aquecedor de fluidos de fluxo rápido  
H-1200**

*Schéma du principe de fonctionnement*

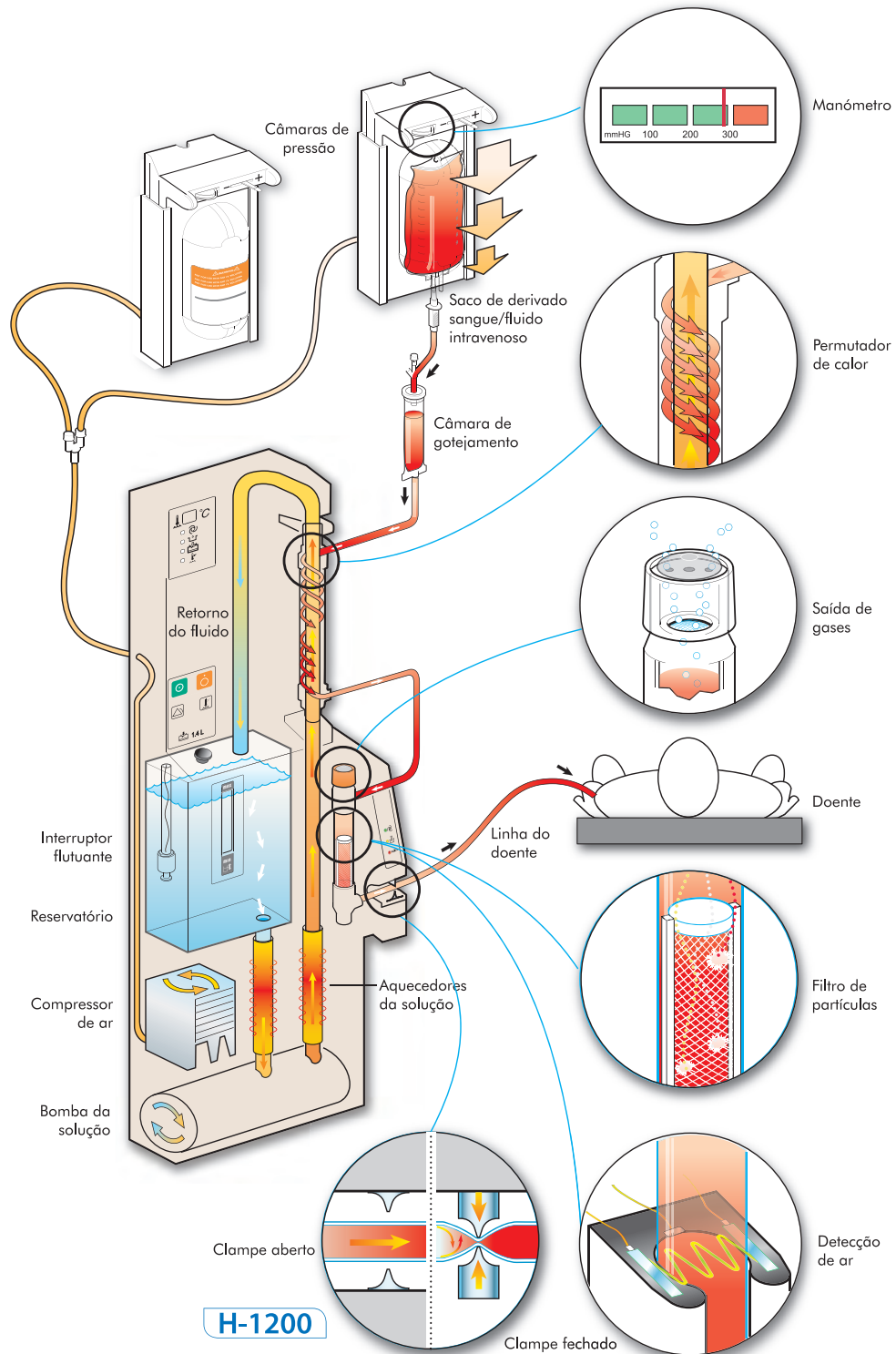

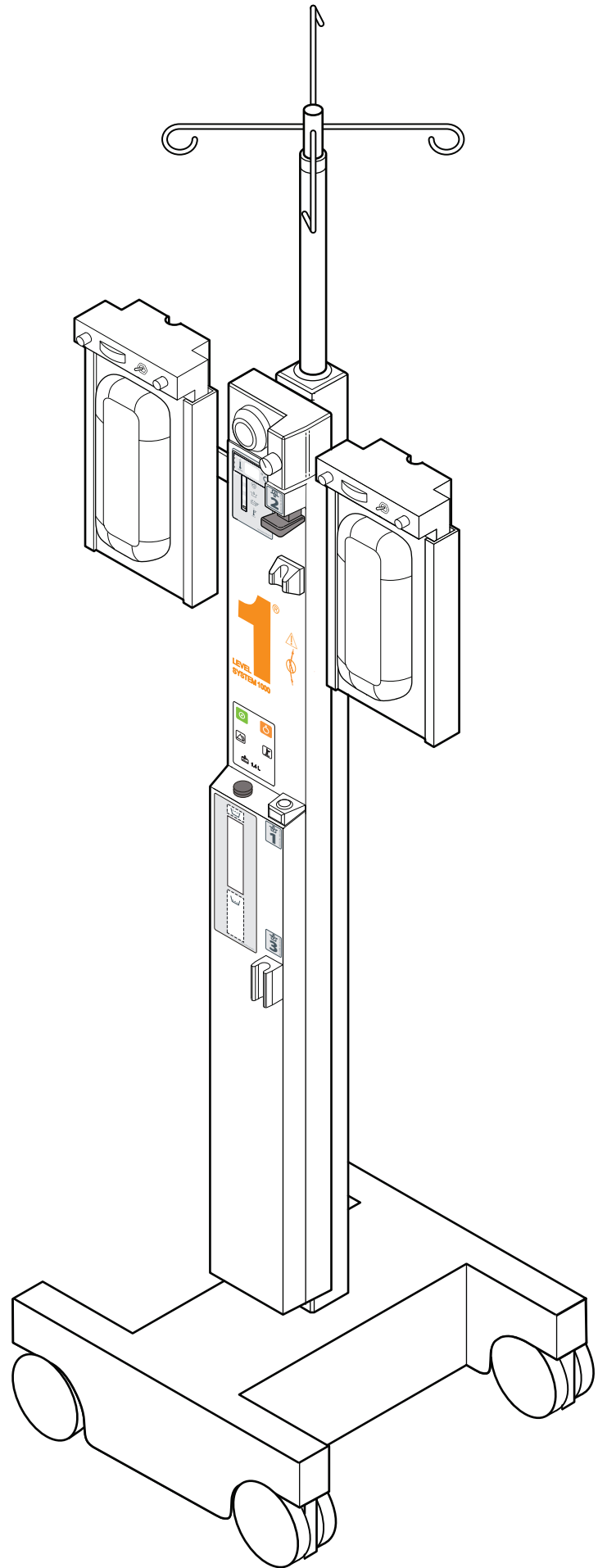
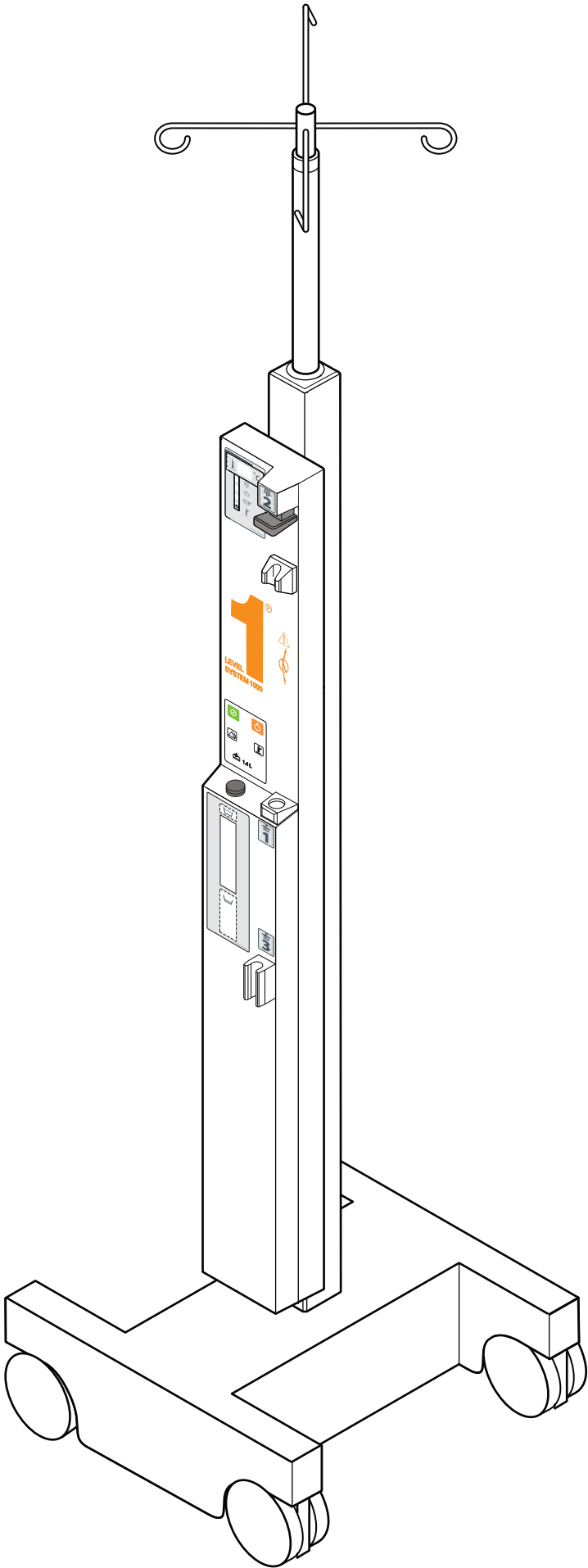

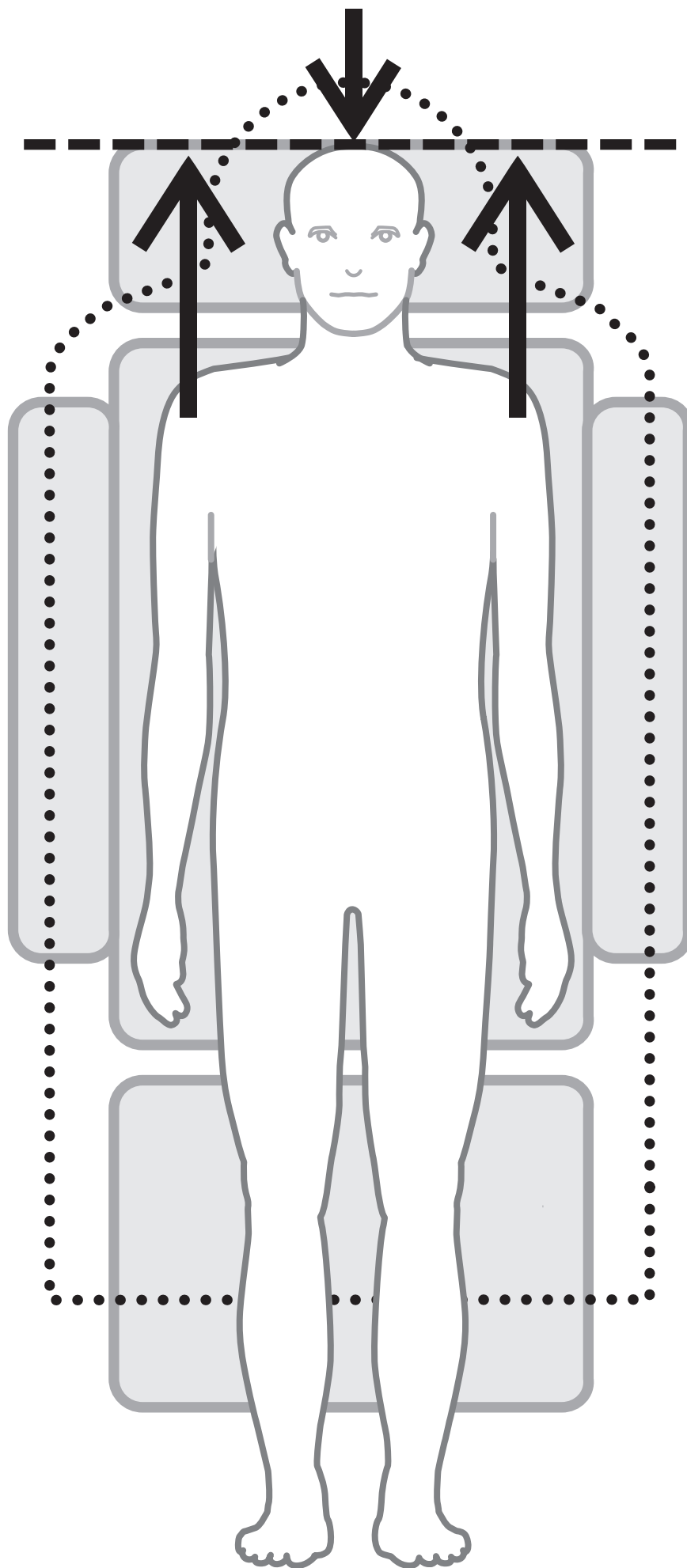

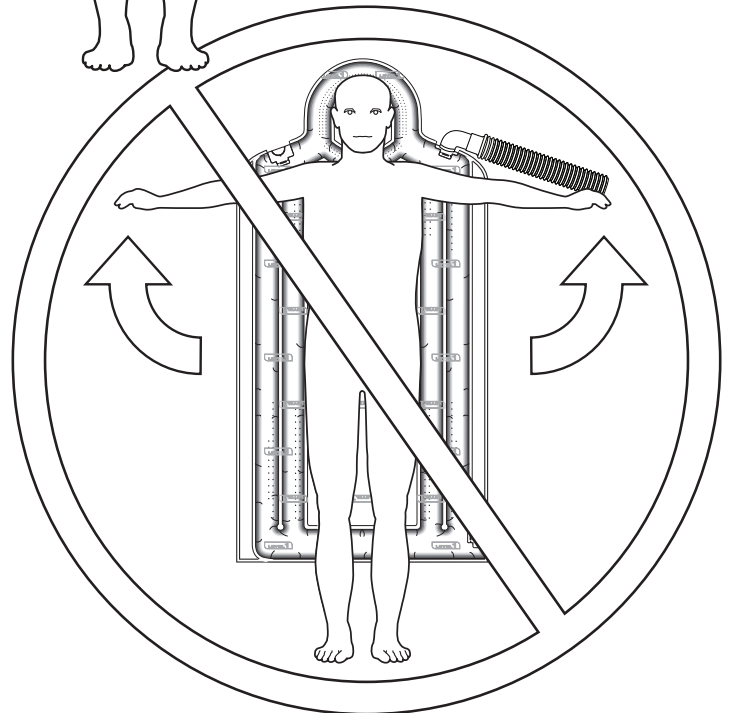
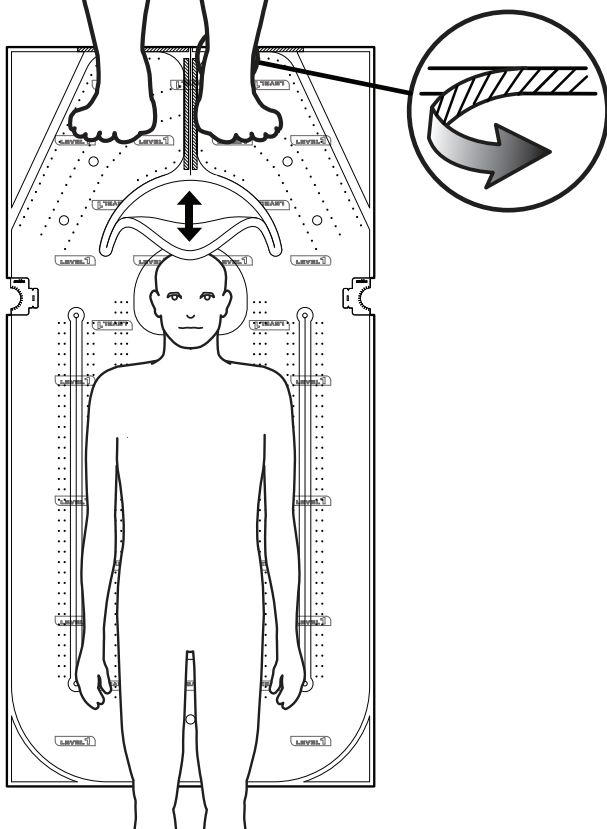
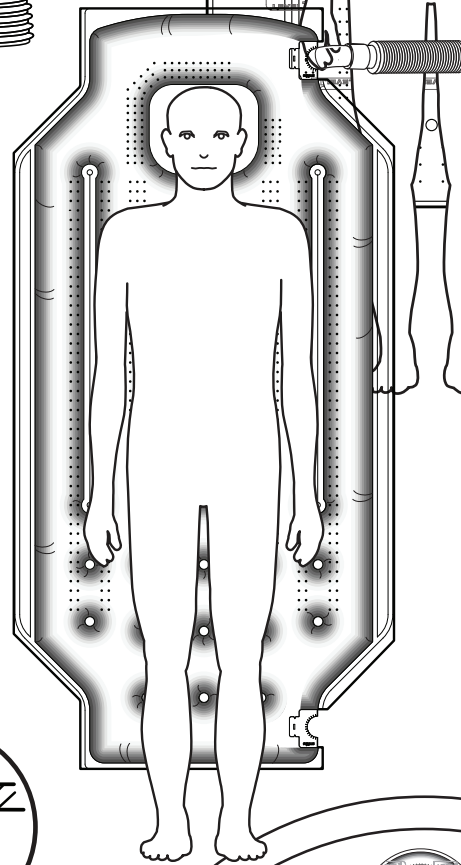
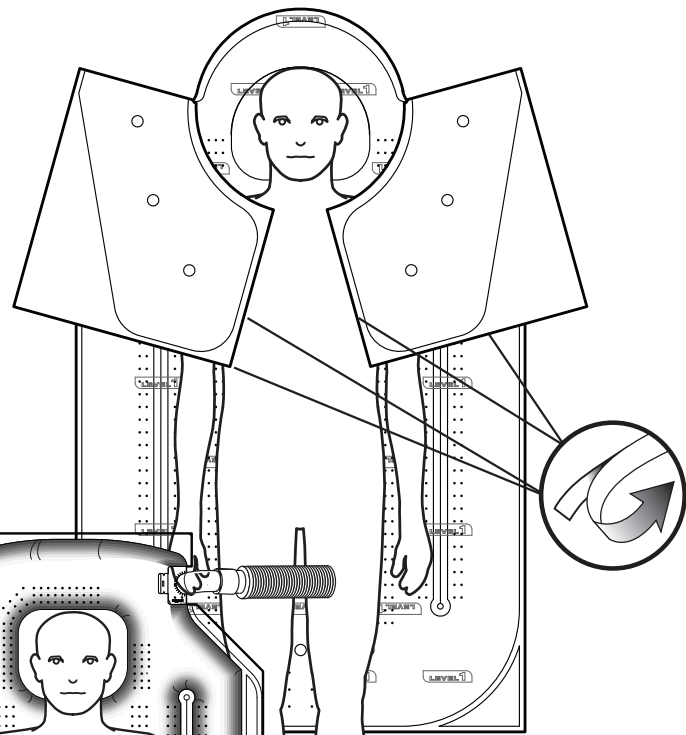
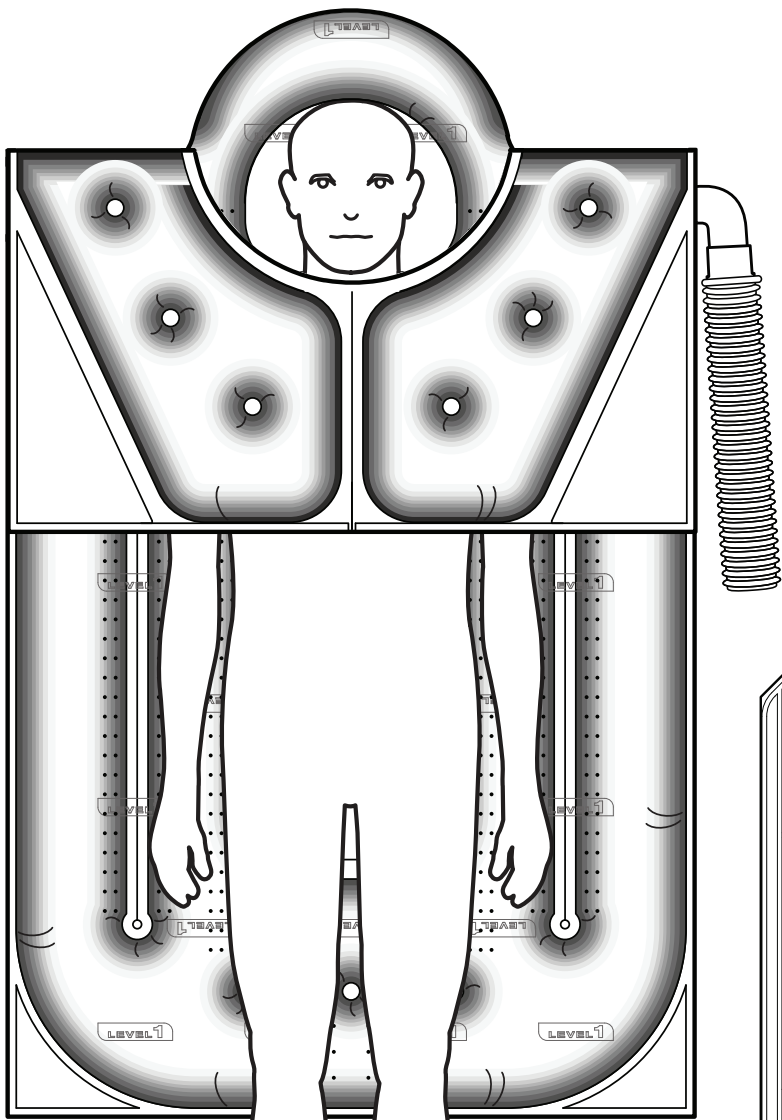

DI-75

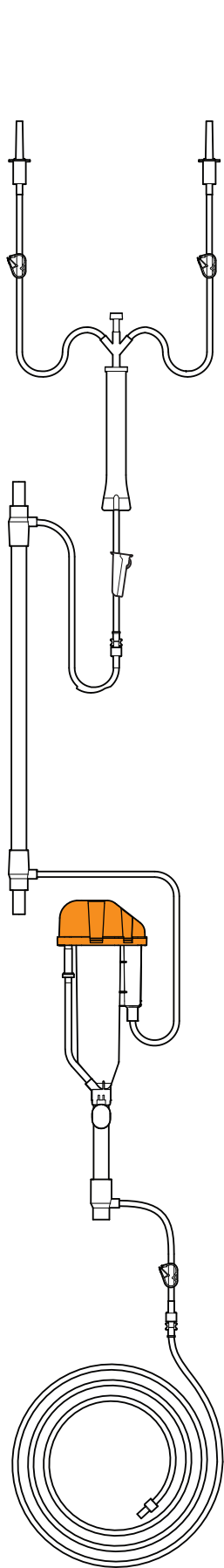

DI-65HL

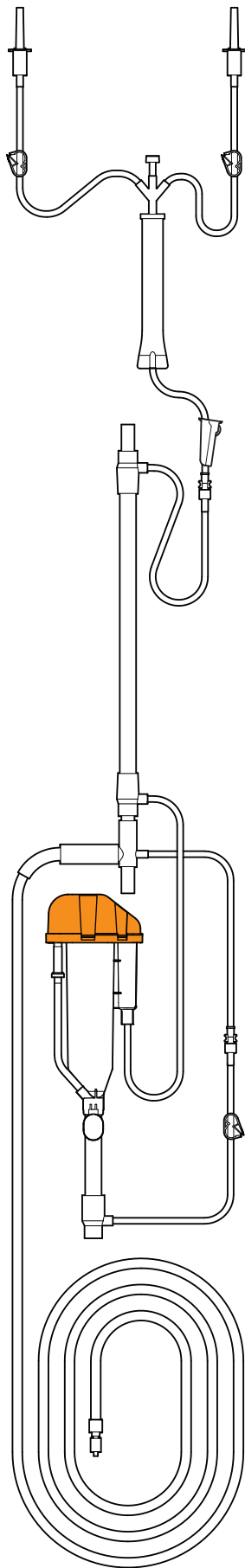

DI-150

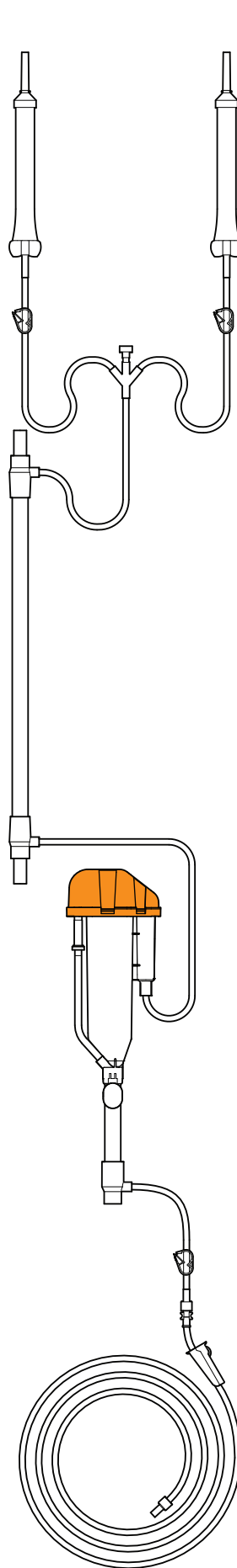

DI-350

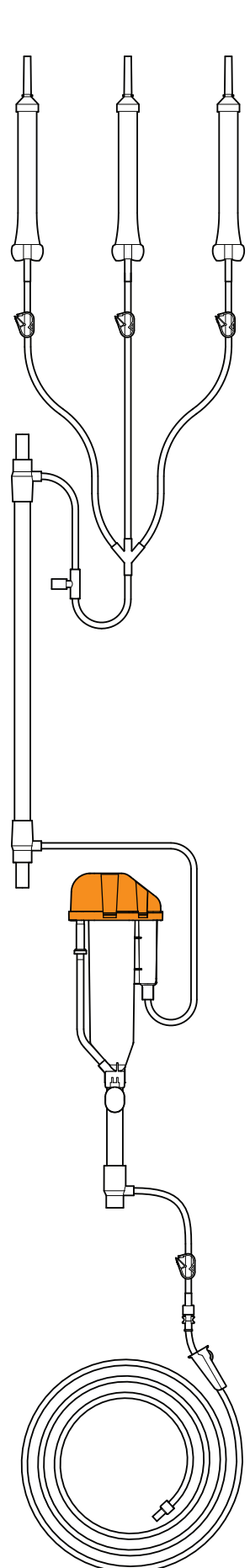

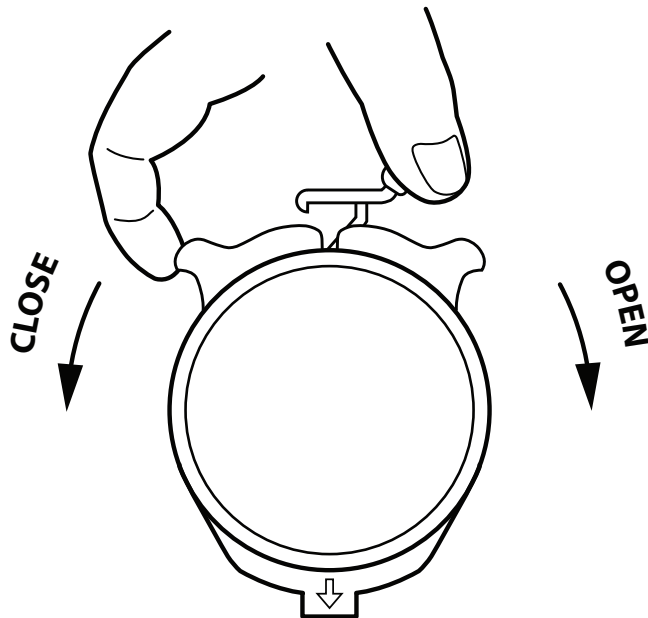
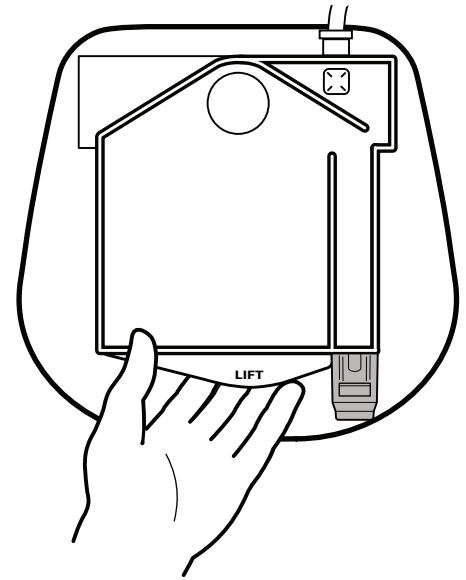
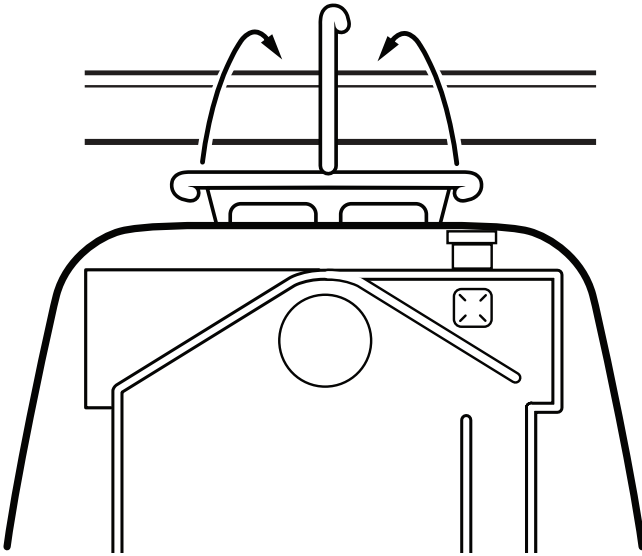
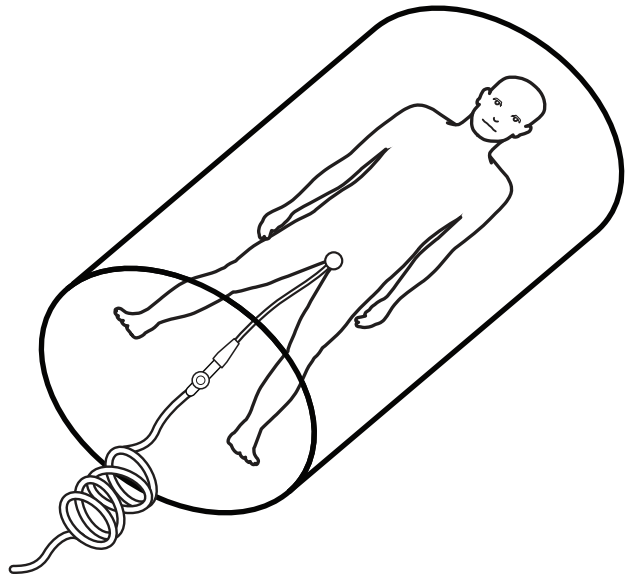
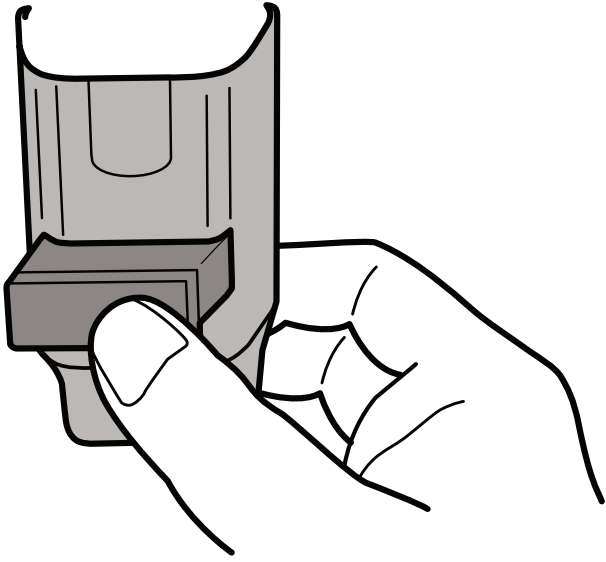



# Charts and Graphs

